

MONGOOSE PRO Shaker

Dual motion combined with configuration flexibility to suit your needs



MONGOOSE PRO Shaker: Flexible, dual motion solids control for the toughest drilling demands

In today's high-cost, high-octane onshore and offshore drilling environments, an optimum solids control package is imperative to reducing costly non-productive time (NPT) while meeting increasingly strict environmental regulations. As the rate of penetration (ROP) changes during drilling, your shakers must be able to keep pace and handle a wide range of solids and fluid compositions. When using premium drilling fluids, you also need a shaker that delivers maximum recovery to convert what otherwise would be waste to beneficial reuse.

With the MONGOOSE PRO¹ shaker, both your drilling budget and the environment come out ahead. The generous throughput capacity of the shaker can handle large cuttings volumes generated by high ROP, saving both rig time and chemical consumption. The normal mode recovers greater amounts of valuable drilling fluid and produces drier cuttings that reduce disposal costs and prolong screen life. Since it processes drill solids more thoroughly than conventional shakers, the cuttings require much less treatment for disposal while reduced dilution means a smaller waste stream.

Combining the power of dual motion with configuration flexibility

Features

- Dual motion:
 - 7.5 G capacity/6.5 G normal
- Single switch controls motion changes during operation
- Utilizes pre-tension composite screens
- Patented ultra-tight seal between screen and screen bed
- Largest net (API) screen area among shakers of similar footprint
- Increased screen visibility
- Can be aligned with up to four shakers
- Comparatively small footprint
- Patented high-capacity distribution box
- Heavy duty, reliable, mechanical deck adjustment system
- Corrosion resistant deck jacks
- Low weir height

Benefits

- Increases fluid capacity and solids conveyance rate when operating in capacity mode
- Maximizes fluid recovery and screen life when operating in normal mode
- Allows for continuous shaker operations when switching between motions
- Facilitates fast screen change out
- Eliminates costly solids bypass
- Promotes safer screen changes and inspections
- Minimizes maintenance costs
- Reduces dilution, chemical requirements
- Recovers valuable drilling fluid for reuse
- Reduces waste stream
- Lowers costs
- Improves environmental performance

The dual-motion MONGOOSE PRO shaker from M-I SWACO, a Schlumberger company, effectively handles the ever-changing solids load during the well construction process while delivering cuttings that meet the tightest environmental restrictions. In the capacity mode, the MONGOOSE PRO shaker manages the high cuttings volumes associated with surface hole sections. As drilling progresses and conditions change, the MONGOOSE PRO shaker can be changed with the flip of a switch to normal mode that allows for longer cuttings retention times in the shaker drying zone. The result includes cuttings that are sufficiently dry and free of contaminants, allowing for full environmental compliance while reducing treatment and disposal costs.

The MONGOOSE PRO dual motion shaker also recovers significant volumes of reusable high-end drilling fluids. What's more, in particularly daunting drilling conditions, up to four MONGOOSE PRO shakers can be aligned on a single skid to deliver even greater efficiencies.

The flexibility and efficiency of dual motion

The ability to quickly and easily switch between motions as cuttings volumes and characteristics change provides operators a distinct advantage, especially in deeper, more challenging wells and on rigs where space is scarce. That's where the revolutionary MONGOOSE PRO shaker separates itself from conventional shakers.

As drilling conditions change, the MONGOOSE PRO dual-motion shaker can be switched easily and quickly. Simply flipping a switch on the control box reconfigures the shaker from Capacity to Normal mode. As an added bonus, with the MONGOOSE PRO shaker you do not have to suspend or shut down operations to reap the distinctive benefits of Capacity and Normal modes.

The high-volume capacity mode

In capacity mode, the MONGOOSE PRO shaker is especially effective while drilling top-hole sections where the generation of heavy, high-volume solids is the norm. In these intervals, shakers need to generate high G-forces to quickly and effectively move high volumes of solids across the screens. During drilling breaks and when fluid viscosity is increased, the capacity mode eliminates the need for screen changes while heading off losses.

The economy of normal mode

The MONGOOSE PRO shaker operates in the gentler normal mode whenever the cuttings volume is reduced, usually in lower sections. Like its capacity counterpart, the normal motion likewise conveys solids quickly out of the fluid pool. When the cuttings reach the discharge screen, the conveyance rate is slowed to allow for extended drying time and recovery of valuable drilling fluid. The efficiency of this motion allows for higher processing rates while increasing cuttings dryness and minimizing haul-off costs.

Key features of the MONGOOSE PRO Shale Shaker



Increased access for inspection, installation, and removal of screens



Deck angle can be adjusted while processing fluid.
Adjustment Range is -3° to +3°

[Back to shale shaker screen homepage](#)

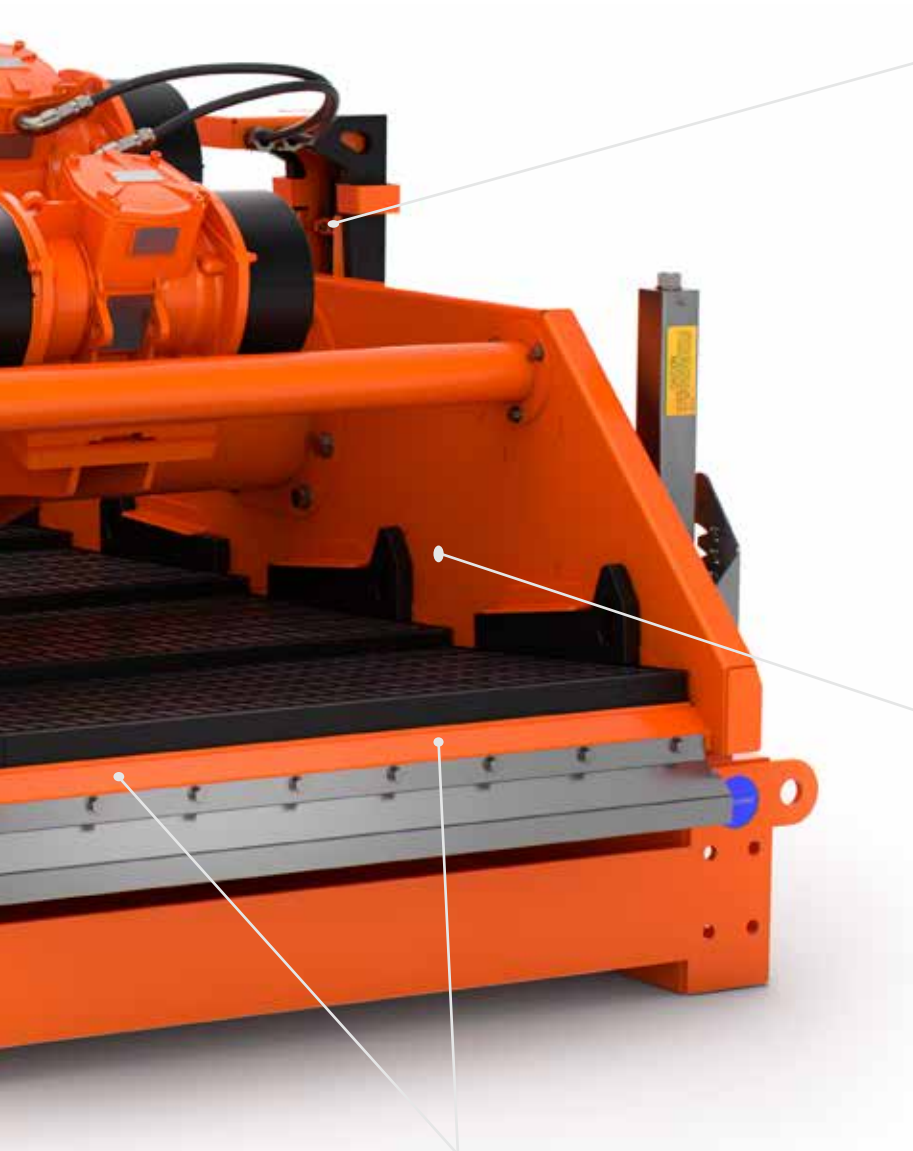

Two oilfield proven 2.5 HP motion generators



Patented ultra-tight seal between screen and screen bed



Largest non-blanked screen area among shakers of similar footprint: 21.2 ft² (1.97 m²)

MONGOOSE PRO Shaker specifications

Dimensions

- Length: 119.8 in (3,044 mm)
- Width: 68.9 in. (1,749 mm)
- Height at 0°: 52.4 in. (1,330 mm)
- Weir height: 29 in. (737 mm)
- Weight: 3,300 lb (1,500 kg)

Screen Deck and Screens

- Screen area
 - Gross: 29.4 ft² (2.73 m²)
 - Net (API): 21.2 ft² (2.0 m²)
- Deck-angle adjustment: +2° to +8°

Vibratory Motion Type

- Normal mode: 6.5 G
- Capacity mode: 7.5G

Motor Specifications

- Voltage: 220-690 VAC
- Speed: 1800RPM/60Hz; 1500RPM/50Hz
- Certifications: UL/cUL, CE, ATEX rated

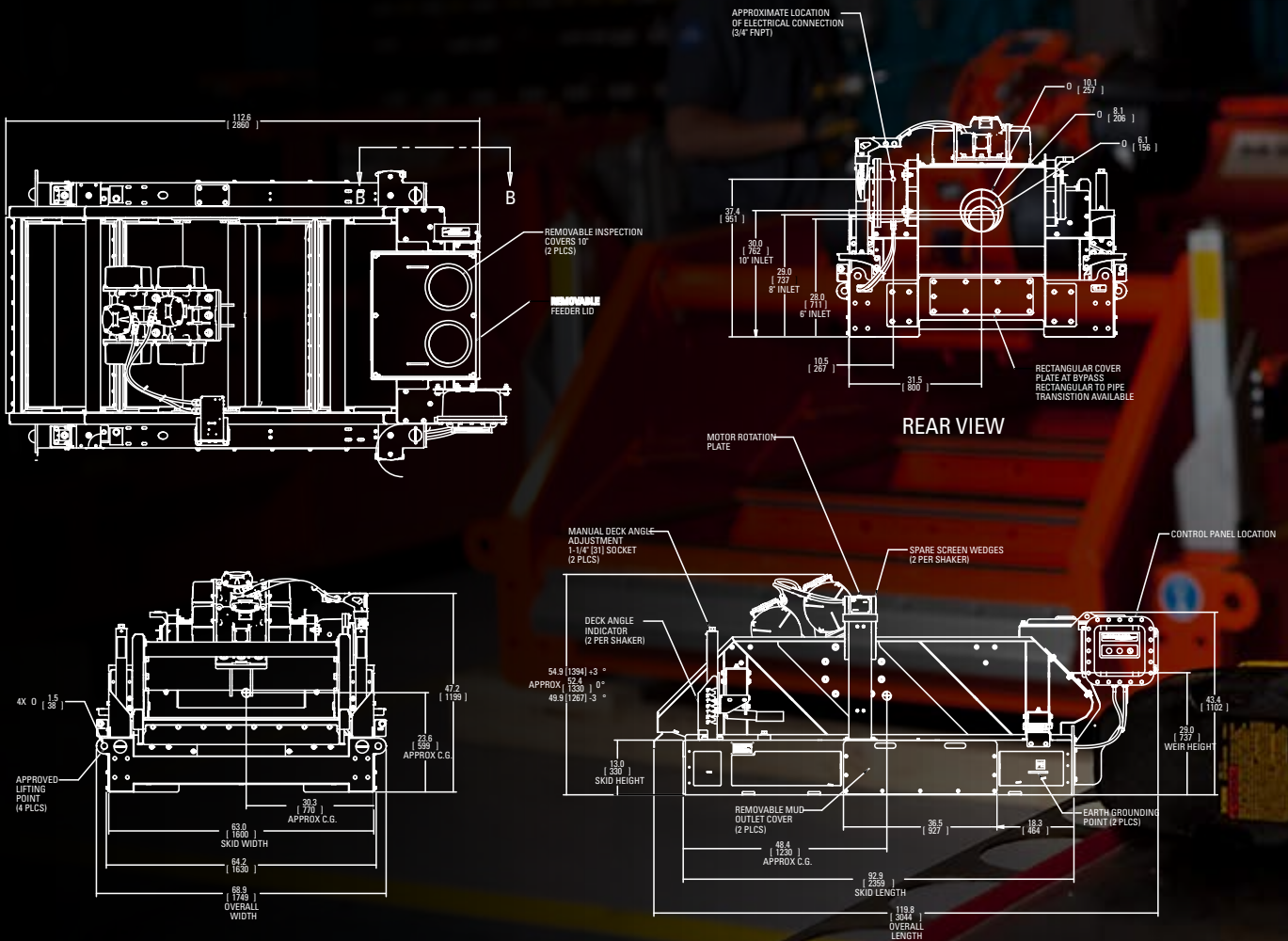

These renderings are for information purposes only and are not actual schematics.



MONGOOSE PRO Dual, Triple and Quad Shakers take performance to a new dimension

Applications often arise that are so challenging that even the ultra-efficient MONGOOSE PRO shaker needs a boost. For those applications that require even more capabilities, two, three, or four MONGOOSE PRO shakers can be pre-aligned at the factory and mounted together on a single skid. The unit is engineered to be moved by a single lift, reducing the time and costs associated with rig moves.

The dual and triple units include a common possum belly, a single flowline connection to the individual shakers, integral feeder

slide gates, and a bypass valve that either balances or completely diverts flow from a shaker. Multiple configurations of mud cleaners also can be added to the dual, triple, or quad shakers. In addition, interconnected walkways between shakers allow safe and easy access.

Available options:

- Multiple header boxes
- Mud cleaner/s
- Lifting frame

MONGOOSE PRO dual shaker

- Length: 124 in. (3,150 mm)
- Width: 145 in. (3,689 mm)
- Height at 0°: 52.4 in. (1,330 mm)
- Weir height: 29 in. (737 mm)
- Weight: 9,400 lb (4,264 kg)

MONGOOSE PRO triple shaker

- Length: 124 in. (3,150 mm)
- Width: 230 in. (5,842 mm)
- Height at 0°: 56.4 in. (1,330 mm)
- Weir height: 33 in. (838 mm)
- Weight: 15,000 lb (6,804 kg)



MONGOOSE PRO Mud Cleaners available for all configurations

To enhance efficiencies even more, the flexible design of the MONGOOSE PRO shaker allows for the installation of mud cleaners for single, dual, triple or quad configurations. Our mud cleaning technology includes D-SANDER[†] units in two or three 12-in. hydroclone assemblies, and D-SILTER[†] units available in six, eight or ten 4-in. twin-hydroclone assemblies. The MONGOOSE PRO mud cleaners operate independently as D-SANDERS, D-SILTERs and flowline shakers.

The MONGOOSE PRO mud cleaners are designed with a low profile of approximately 64 in. (1,626 mm) to the top of the trough. This compact design minimizes height requirement and the overall rig-site footprint. The integral bypass between the shaker and D-SANDER/D-SILTER allows for inspection and maintenance without ladders or scaffolds.

MONGOOSE PRO mud cleaner

- Length: 119.8 in. (3,044 mm)
- Width: 93.8 in. (2,381 mm)
- Height: 98.6 in. (2,503 mm)
- Weir height: 29 in. (737 mm)
- Weight: 6,200 lbs (2,820 kg)



MONGOOSE PRO Composite Screens provide longer life, more usable area

The intrinsic cost-effective performance of the MONGOOSE PRO shaker is enhanced even more when combined with the M-I SWACO high-capacity composite shaker screens, the most rugged, long-lasting and most efficient screens available.

Standard to the MONGOOSE PRO shaker and unique in the industry, the proven composite screens offer significant fluid capacity, excellent resistance to blinding, drier solids discharge and a large net usable screen area.

These highly engineered screens also provide resistance to corrosive drilling fluids. Composite construction creates an ultra-tight seal between the screen and screen bed, eliminating costly solids bypass. The unique screen locking mechanism wedges the screen firmly in place and allows for simple and safe removal of the screen for repair or replacement.

Mi SWACO
A Schlumberger Company





MONGOOSE PRO Shaker proves itself in the field

Southern Louisiana: MONGOOSE PRO shaker reduces drill disposal costs over \$23K by reducing volumes 47%

The Situation

A rig in Louisiana was selected for a shaker replacement trial comparison. The rig had just completed drilling a well and was prepared to move over approximately 50 yards and drill a similar well. Due to extensive dilution, and haul off costs, the rig-owned flow line shaker was replaced with a MONGOOSE PRO shaker from the M-I SWACO rental fleet. A complete evaluation of the solids control efficiency and waste management costs associated with this drilling program was conducted to prove the additional performance achieved by incorporating new solutions into an existing drilling program.

The Solution

The new generation MONGOOSE PRO shaker was engineered to operate in both the normal and capacity modes. The normal mode produces 6.5 G, while the capacity mode produces 7.5 G. Because drilling rates and conditions change and demands are increasing in modern day drilling, solids control equipment must be able to handle a wide range of solids and fluid compositions. While drilling, maximum fluids recovery is of critical concern. The MONGOOSE PRO shaker was designed with performance to meet the ever demanding requirements of today's drilling operations. M-I SWACO identified two critical criteria to assess overall shaker performance: fluid conductance, and cuttings dryness.

The Results

The MONGOOSE PRO shaker proved more than capable of handling the 12.25" section with an average ROP of 50 ft/hr and consistent flow rates at or near 660 gal/min, all while dressed with JMONXR200C mesh screens at a +1° deck angle and drilling fluid weighing in at 9.2 PPG with a 40-45 second vis. Further to the optimal performance exhibited towards preserving the fluids rheology and low gravity solids (LGS), the MONGOOSE PRO shaker drastically reduced disposal volumes, transportation and ultimately cost by nearly half, and volumes were reduced by an astonishing 47%. Once both wells were drilled, data for the disposal volumes and cost were collected. Testing results and final evaluation further confirmed the superior performance of the MONGOOSE PRO shaker and the ability to screen finer, earlier in the well, without sacrificing ROP or Circulating Rate.

Put the MONGOOSE PRO shale shaler to work for you

To find out more about how our MONGOOSE PRO shale shaker is working for our other customers worldwide, contact your local M-I SWACO representative.



ONLINE RESOURCES

Solids Control

www.miswaco.com/solidscontrol

Shakers

www.miswaco.com/shakers

MONGOOSE PRO Shale Shaker

www.miswaco.com/mpro

DURAFLO Screens

www.miswaco.com/screens

This information is supplied solely for informational purposes and M-I SWACO makes no guarantees or warranties, either expressed or implied, with respect to the accuracy and use of this data. All product warranties and guarantees shall be governed by the Standard Terms of Sale. Nothing in this document is legal advice or is a substitute for competent legal advice.

Mi SWACO
A Schlumberger Company